

LETBANE PÅ RING 3

*Dansk Ståldag - 12. november 2015
- v. Mette Neimann*



**GOTTLIEB
PALUDAN**
ARCHITECTS

KOLLEKTIV TRANSPORT I STORKØBENHAVN



OMFANG

- › 28 km strækning
- › 28 stationer - heraf 6 skiftestationer
- › 10 letbanebroer og 7 stibroer
- › 3 tunneler
- › støttevægge og landskabsbearbejdning
- › 9 trapper og 1 elevator
- › 8000 m2 Kontrol- og vedligeholdelsescenter
- › 16 omformerstationer

28 10 3 9 8000 16

FAKTA



- › 43.000 daglige passagerer eller 13-14 mio passagerer om året, stigende til 17-18 mio om året i 2032
- › 5 min drift i dagtimer, 10 min drift i aftener og weekender
- › ca 55 min rejsetid fra Ishøj til Lundtofte (gennemsnitlig 30 km/t)

AFTALEGRUNDLAG



Samarbejdsaftale 2011

- › 11 Ringby-kommuner (34%)
Lyngby-Taarbæk, Gladsaxe, Herlev,
Albertslund, Rødovre, Glostrup,
Brøndby, Hvidovre, Vallensbæk, Ishøj,
Høje Taastrup
- › Region Hovedstaden (26 %)
- › Transportministeriet (40%)

Udredning 2013

- › Hovedstadens Letbane

PROJEKT- ORGANISATION

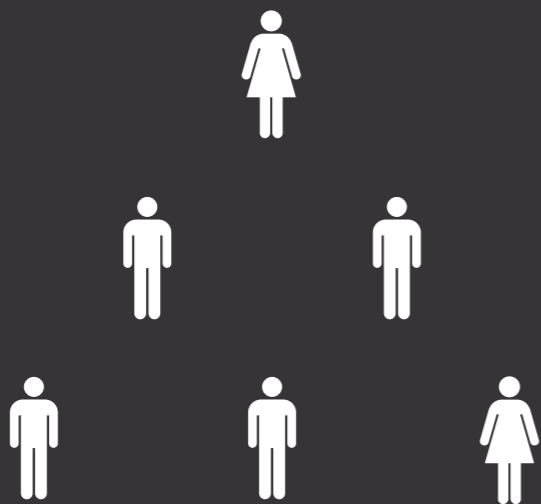

Arkitektur og Landskab

- › Gottlieb Paludan Architects
- › GHB Landskabsarkitekter
- › Kontrapunkt
- › COWI

Øvrige rådgivere

- › Veje og Ledninger
- › Transport System
- › VVM
- › Arealer og Rettigheder
- › Landmåling

TIDSPLAN

- › PQ ultimo 2015
- › Forventet udbud 1. halvår 2016
- › Forventet anlægslov 1. halvår 2016
- › Udførelse 2017 - 2021

2014 —○—○—○—○—○—○—○—○—○— 2021

DESIGN STRATEGI



“ *Letbanen skal fremme den kollektive trafik og dermed fremkommeligheden på tværs af byfingre.*

- HOVEDSTADENS LETBANE

“ *Letbanen skal fremme
byudviklingen.*

- HOVEDSTADENS LETBANE

“ *Letbanen skal
anlægges inden for den
fastlagte økonomiske
ramme.*

- HOVEDSTADENS LETBANE

“ *Det skal være
‘verdens bedste letbane’* ”

- HOVEDSTADENS LETBANE



“ *Flot og klassisk design uden at være prangende.*

Pålidelig, robust og driftsikker.

Folkelig og økonomisk overkommelig.

Langtidsholdbar.

BRANDPLATFORM

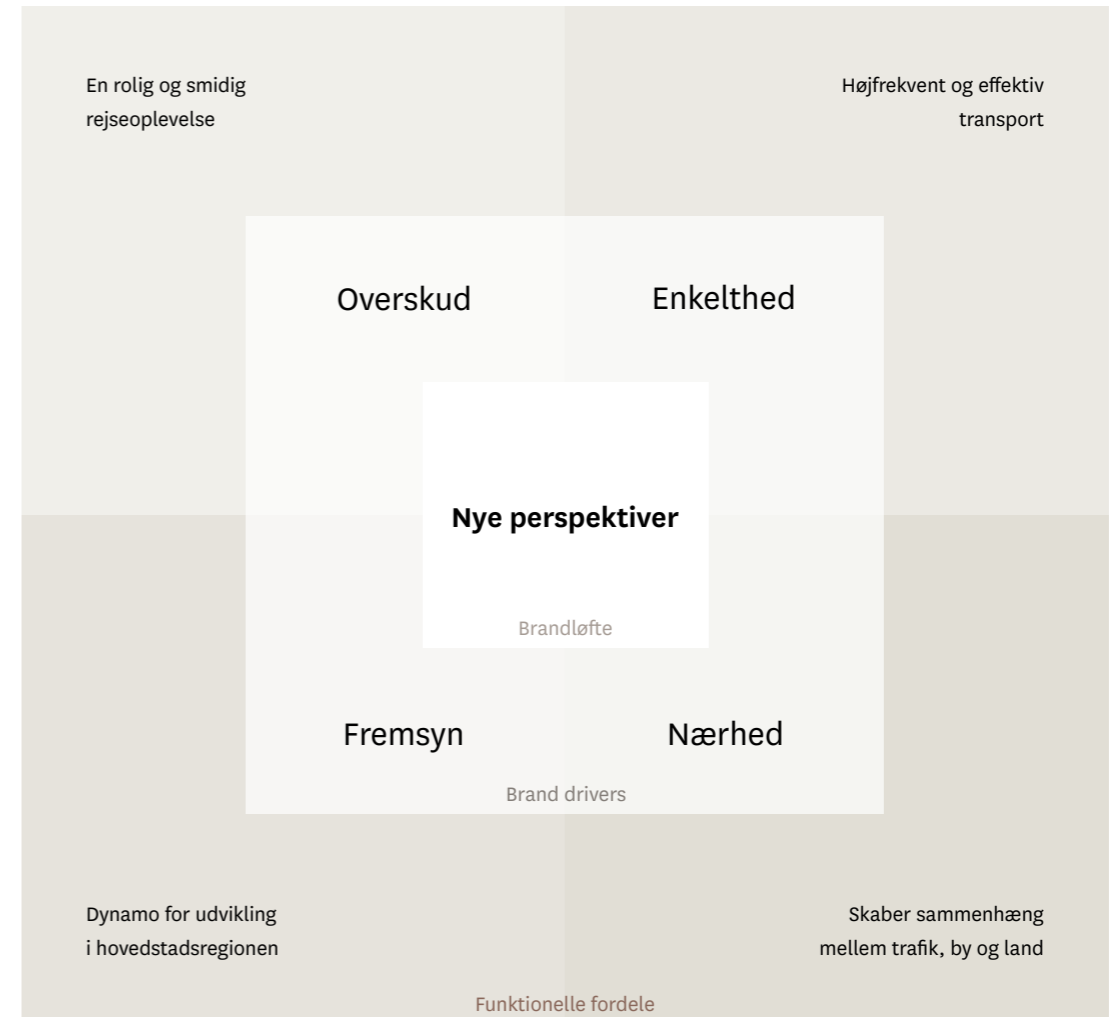

ARKITEKTONISKE MÅL



- › smukt arkitektonisk særkende
- › tydelig kerneidentitet forankret i et gennemgående og ensartet designkoncept, der kan genfindes i alle elementer
- › design, som kan integreres og samtidig tilføre værdi og karakter i forskellige bymæssige og landskabelige sammenhænge

ARKITEKTONISKE MÅL

- › tidløst design med varig kvalitet og med materialer, der tåler slid og patinerer smukt
- › design, som sikrer en hensigtsmæssig drift
- › oplevelser både indefra og udefra



ARKITEKTONISKE MÅL



STRÆKNING



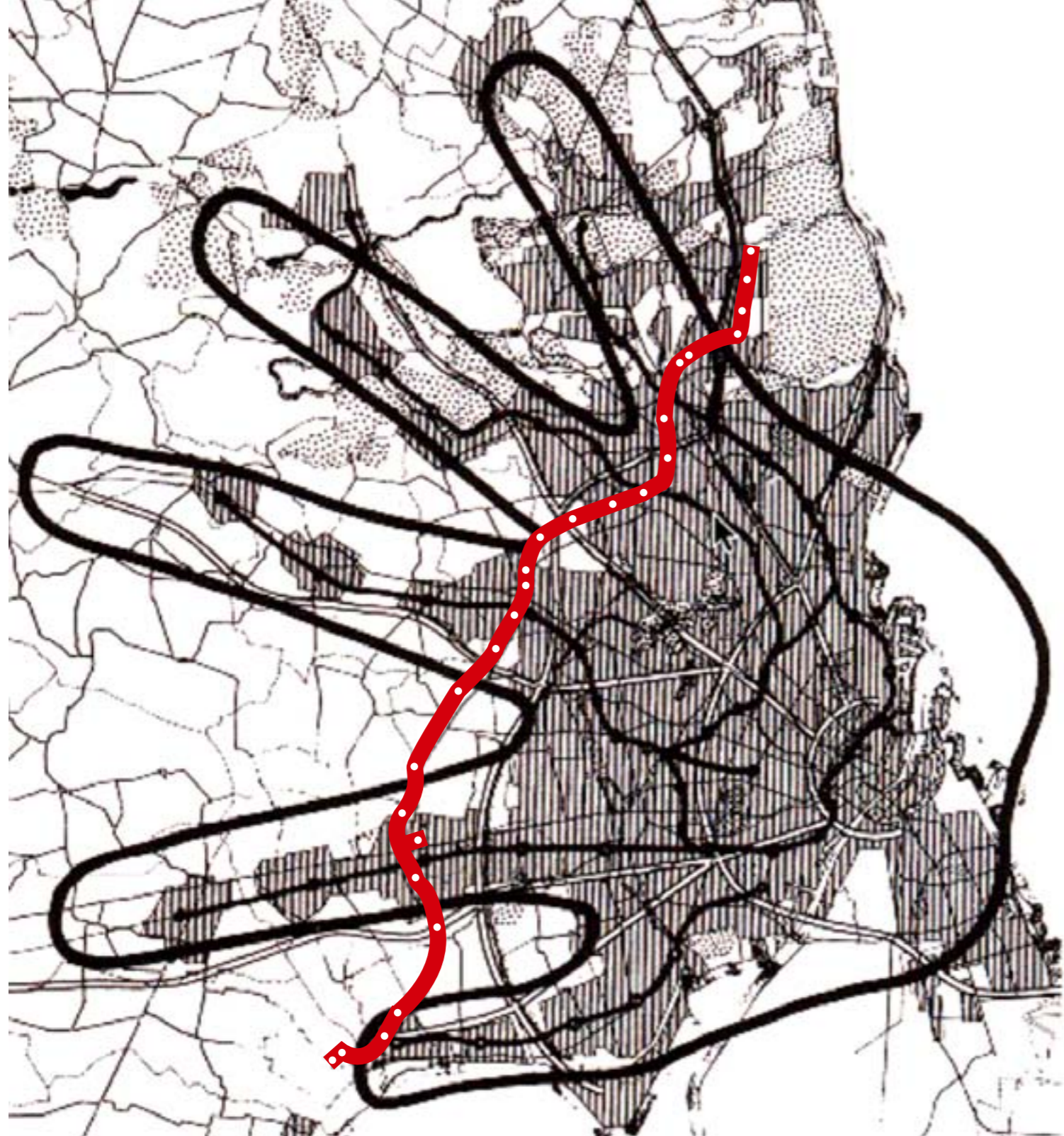

ANALYSE AF STRÆKNING

infrastruktur



det blå/grønne landskab



mellemlandet

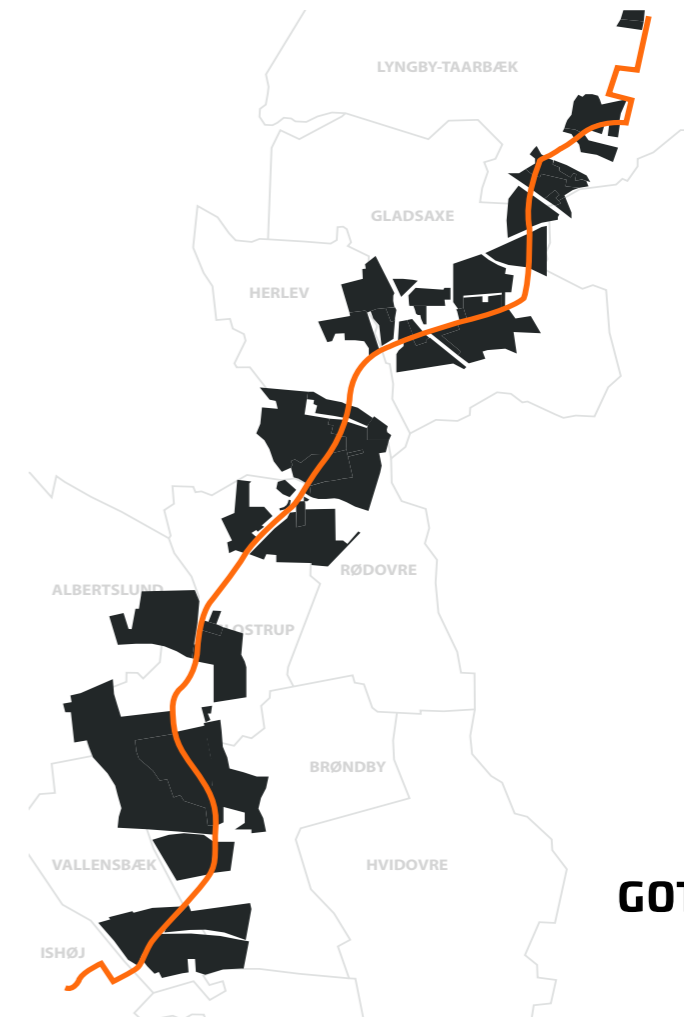

UDVIKLINGSOMRÅDER

beplantning ryddes

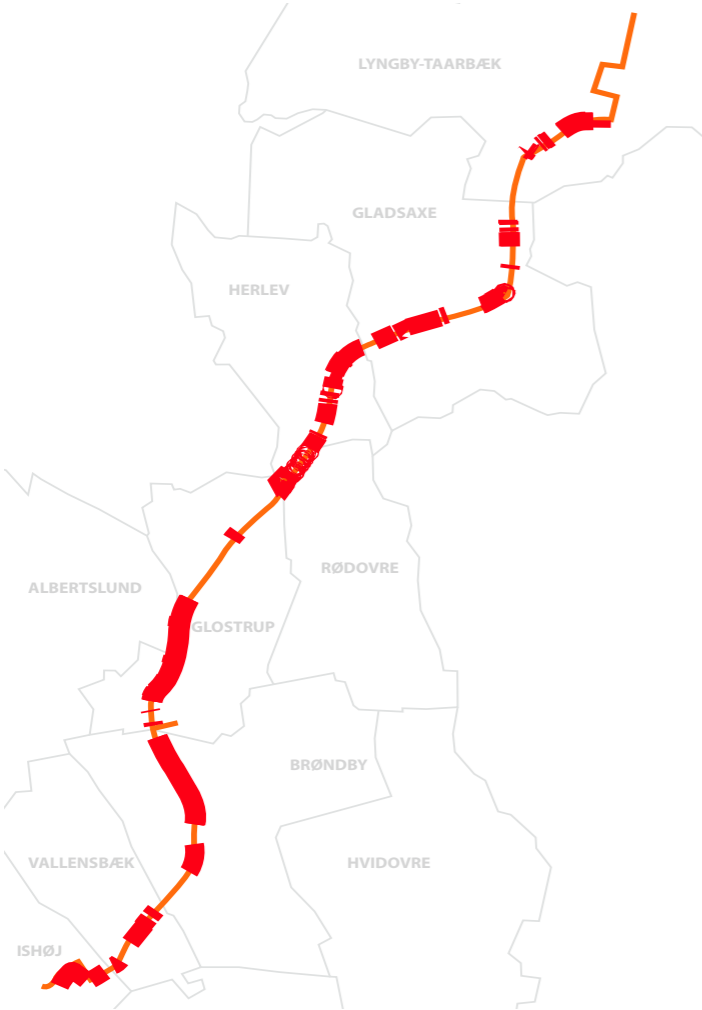

byudviklingsområder

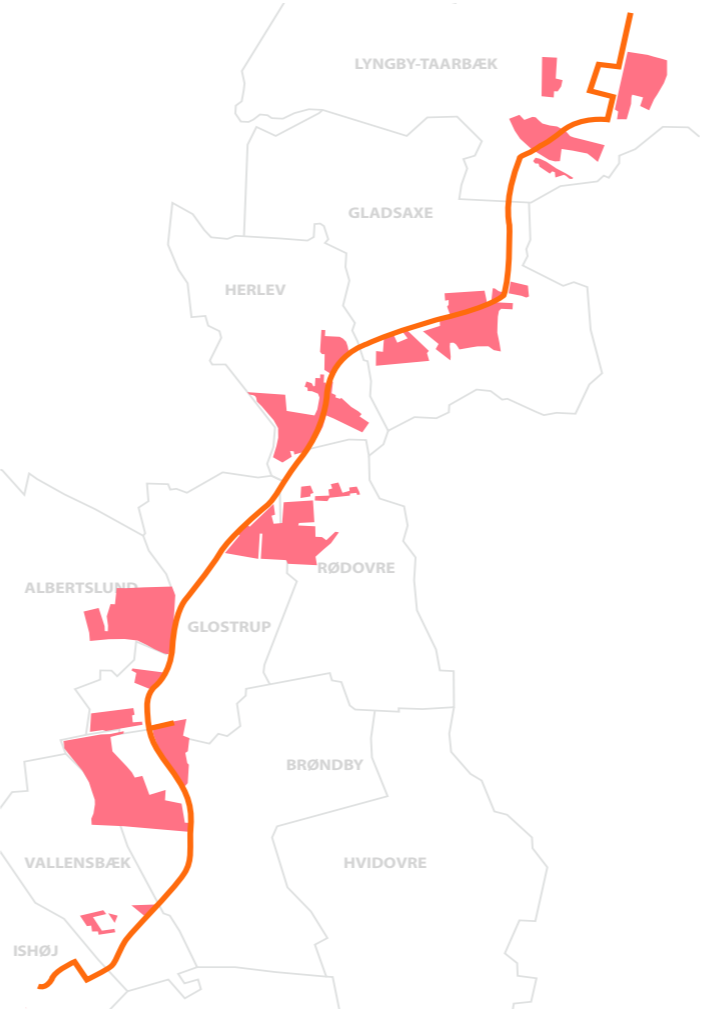

ny forside

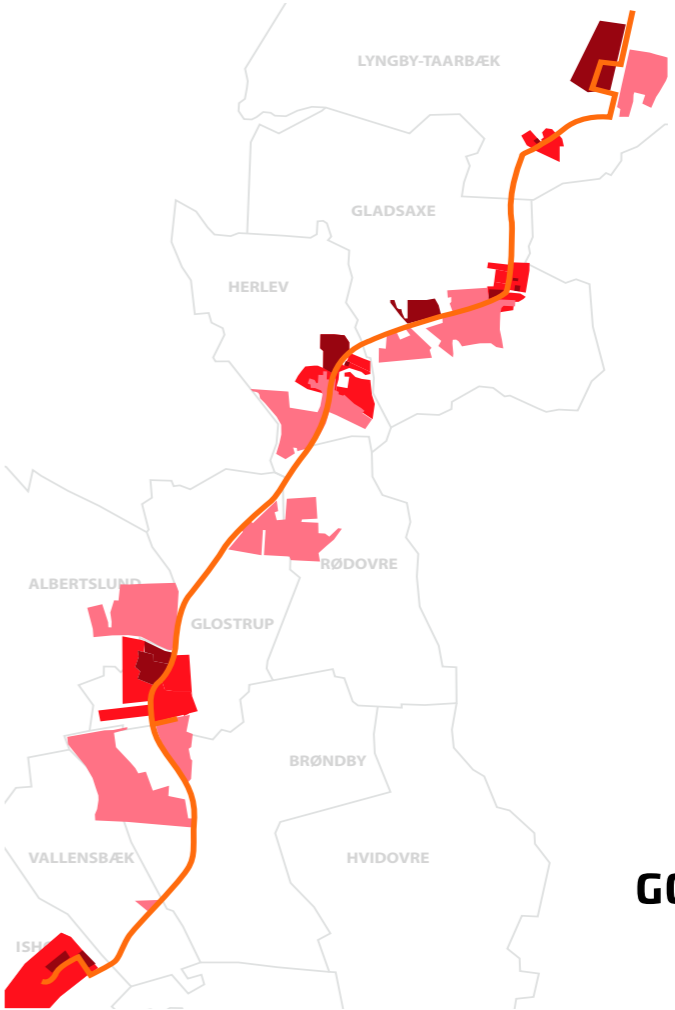

NY FORSIDE

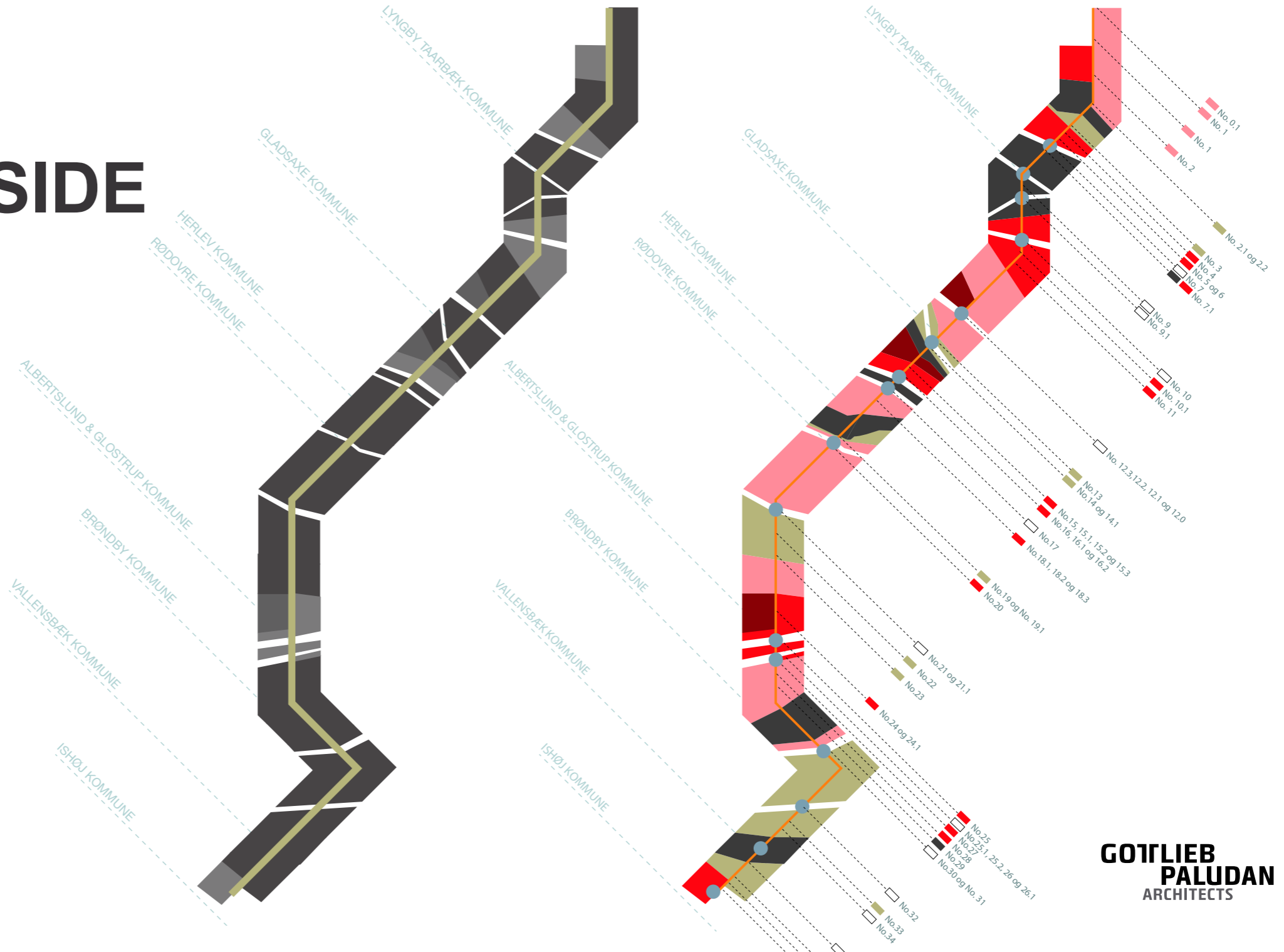

POTENTIALER

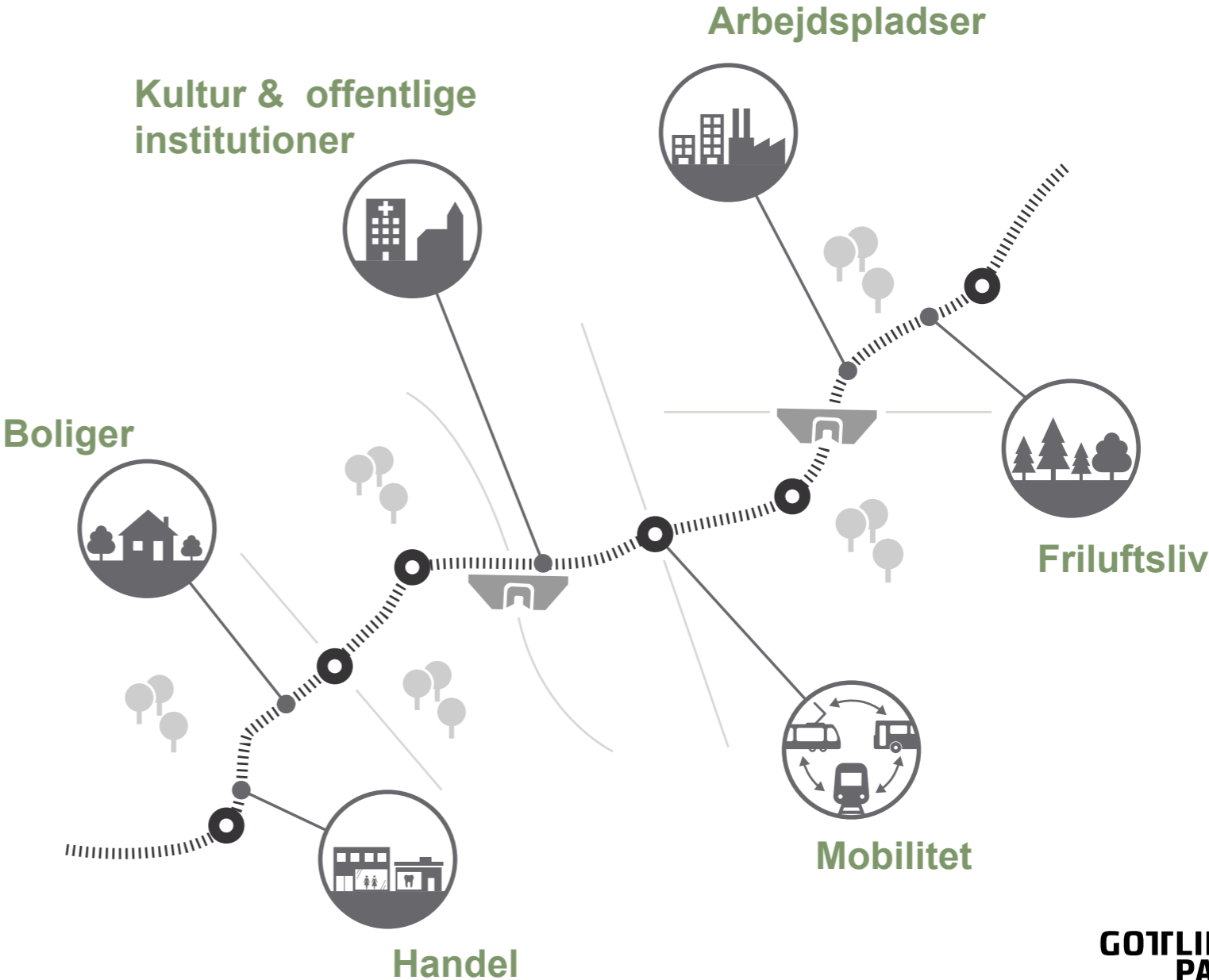

STATIONER





LINJEFØRING

- Tog
- Bus

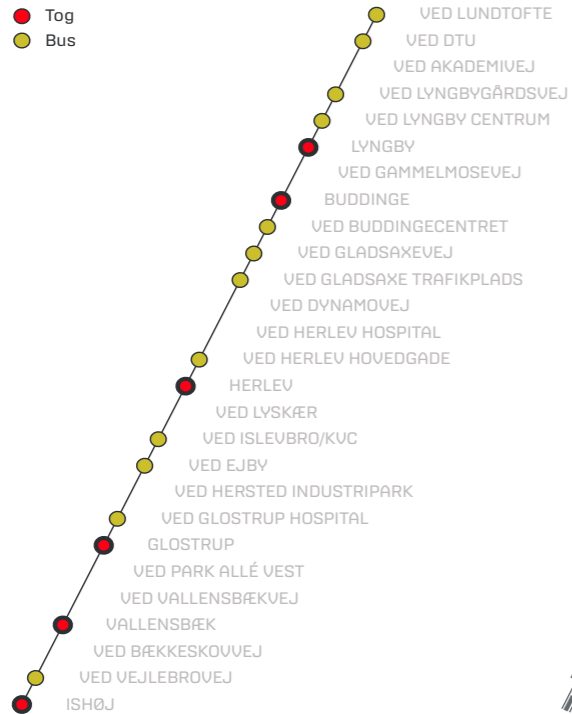

Omskift

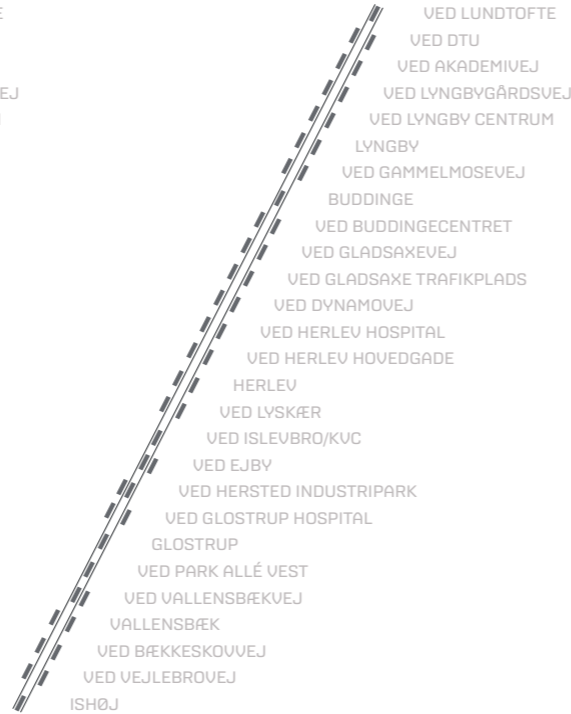

Perroner

- Letbane
- Vej

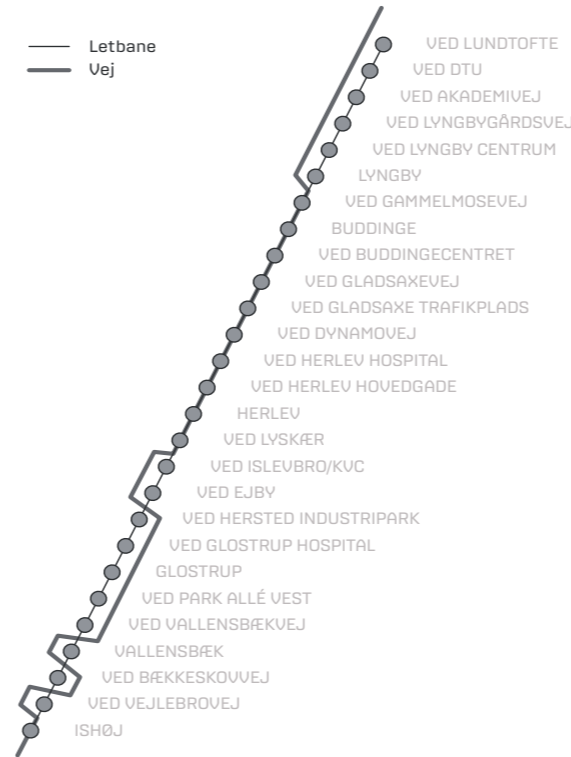

Placering

- Lille
- Mellem
- Stor

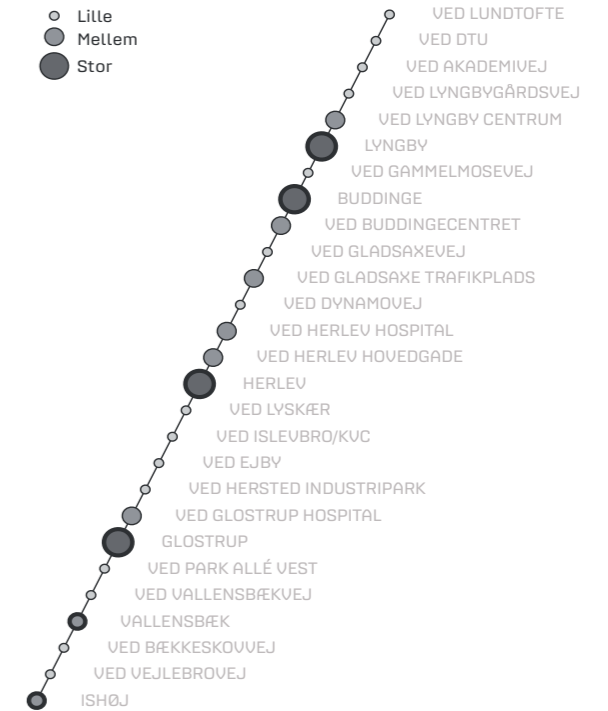

Størrelser

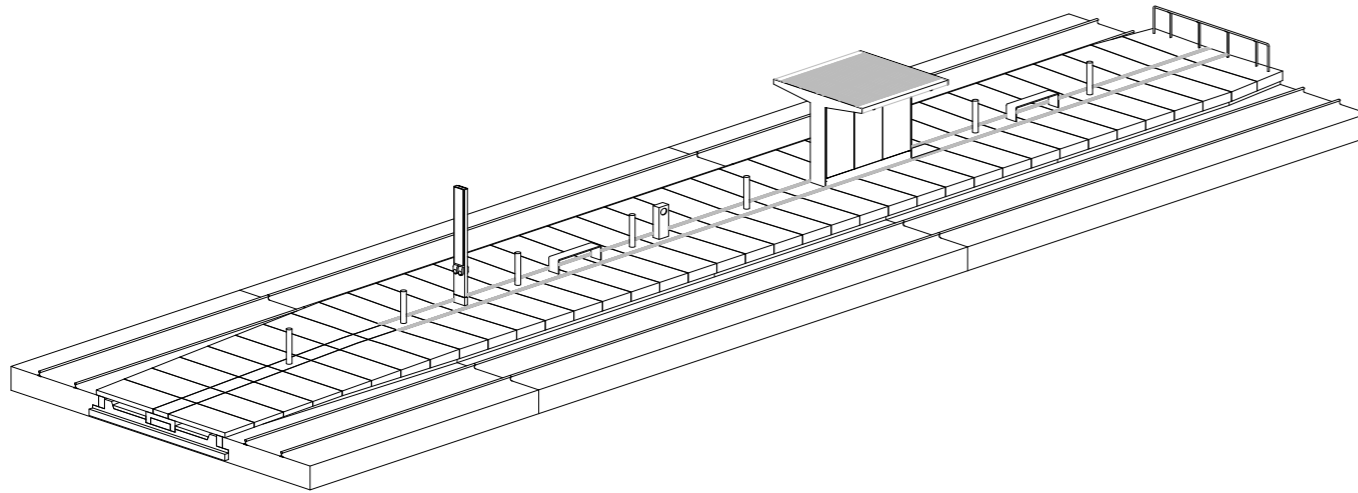

- › enkelt, modulært og fleksibelt design, som kan imødekomme forskellige behov og størrelser, også over tid
- › selvforklarende og intuitivt at benytte
- › integreret design med så få elementer som muligt
- › tilgængeligt for alle

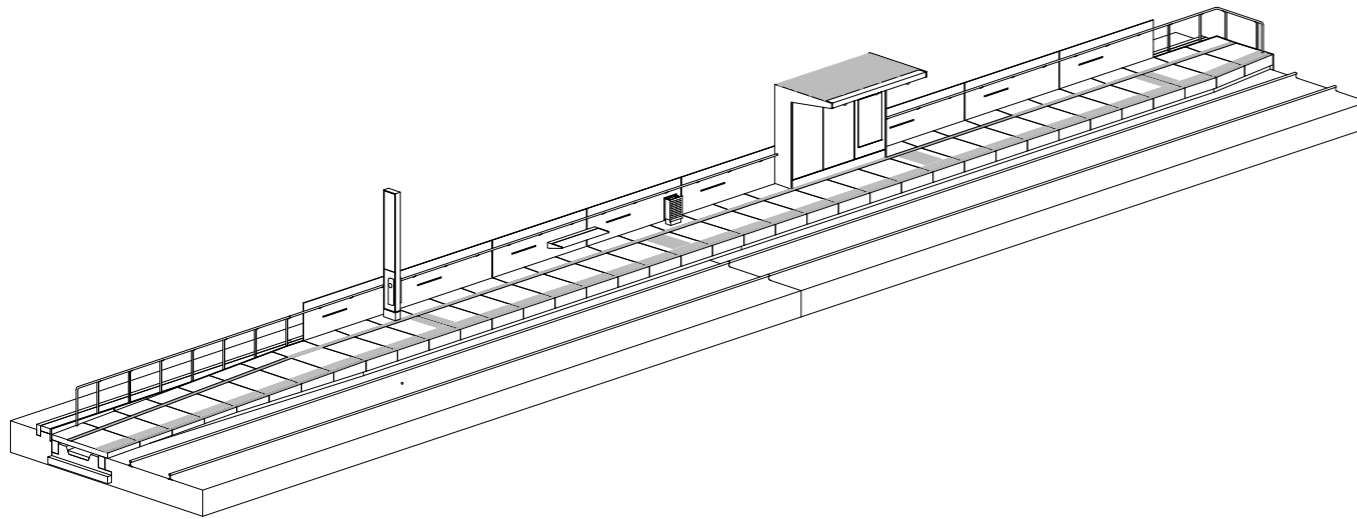

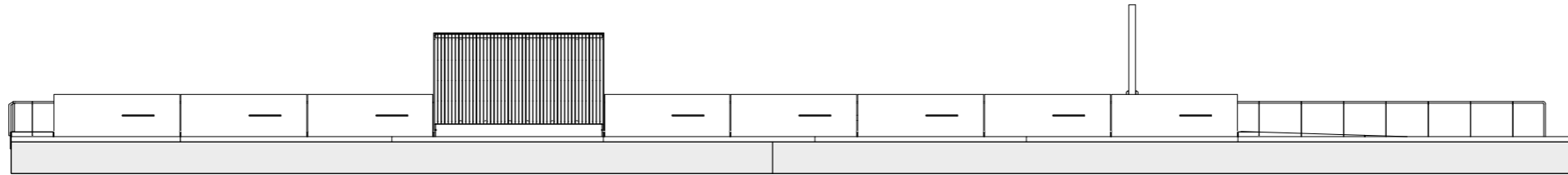

Elevation L1-L1

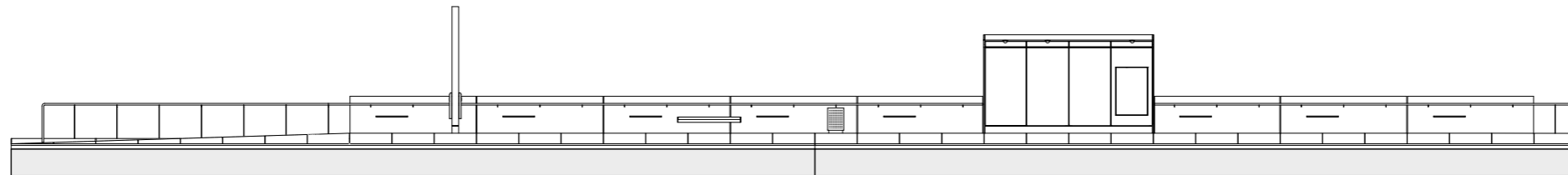

Elevation L2-L2

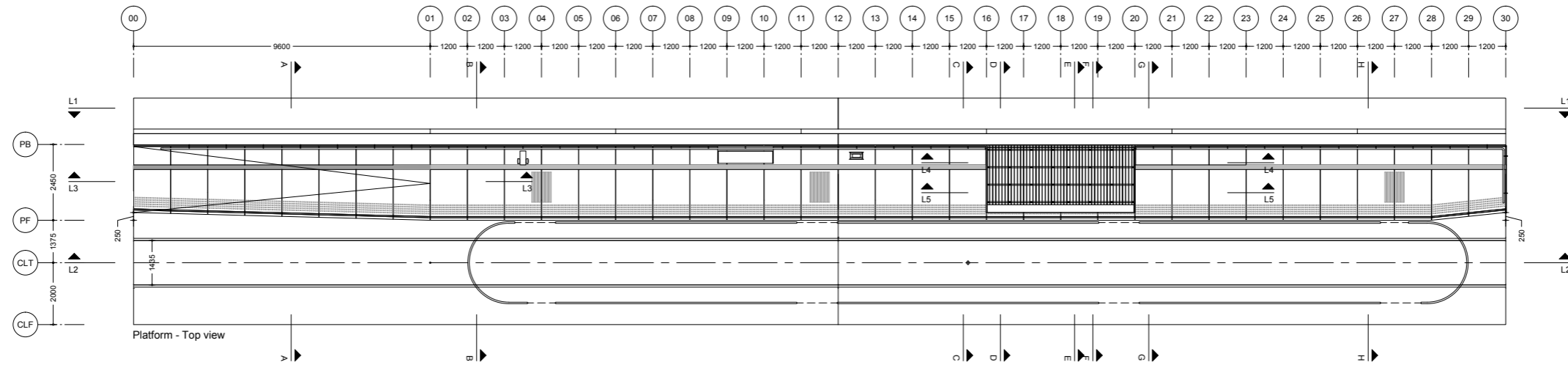

Platform - Top view



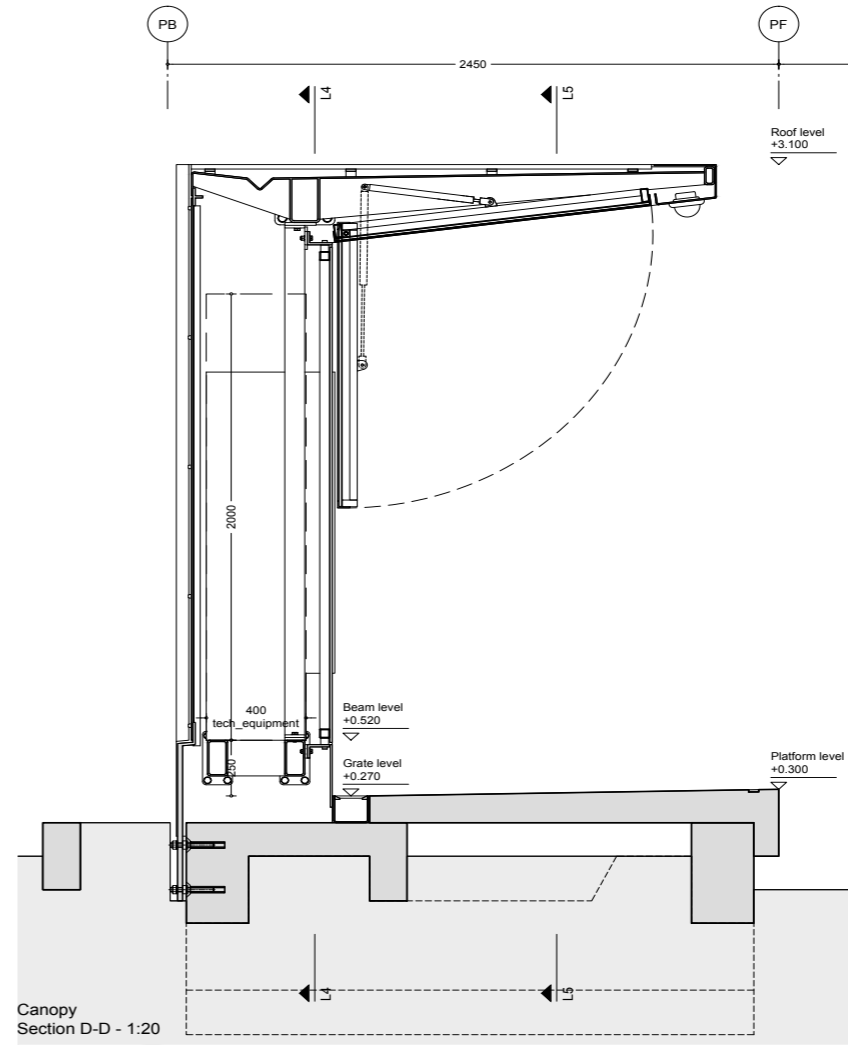
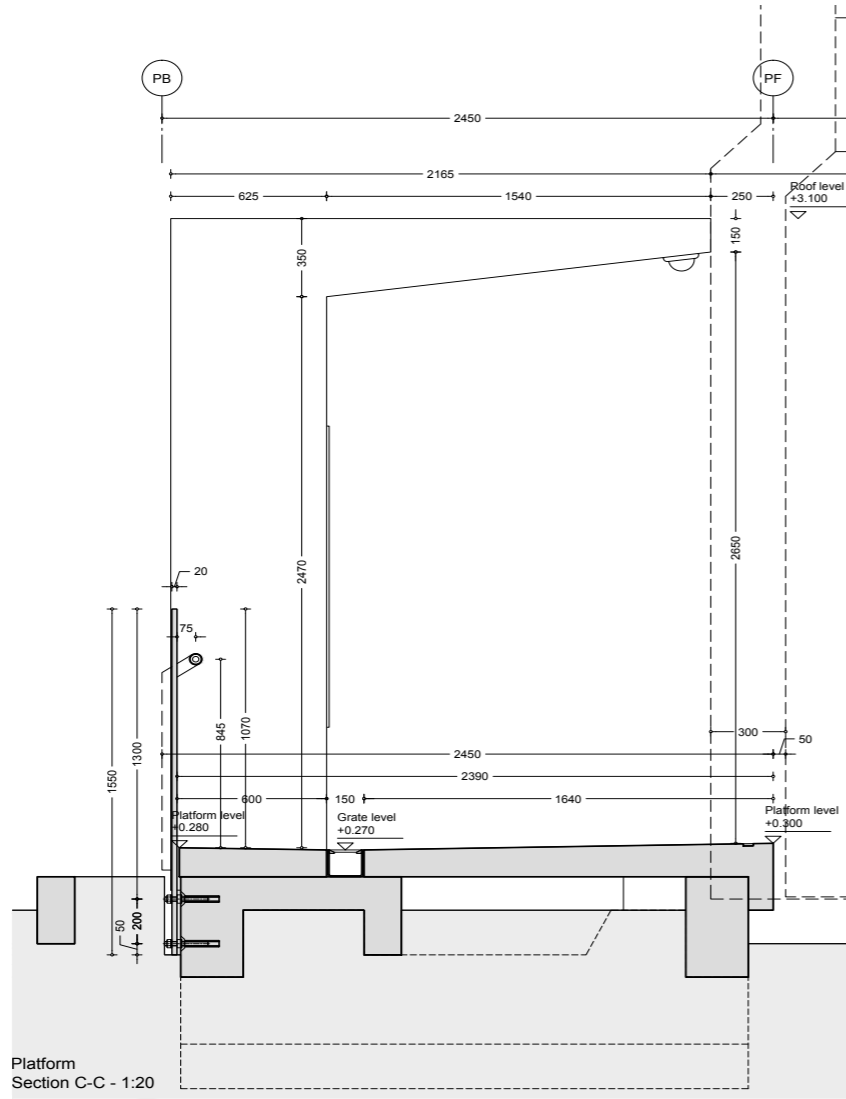

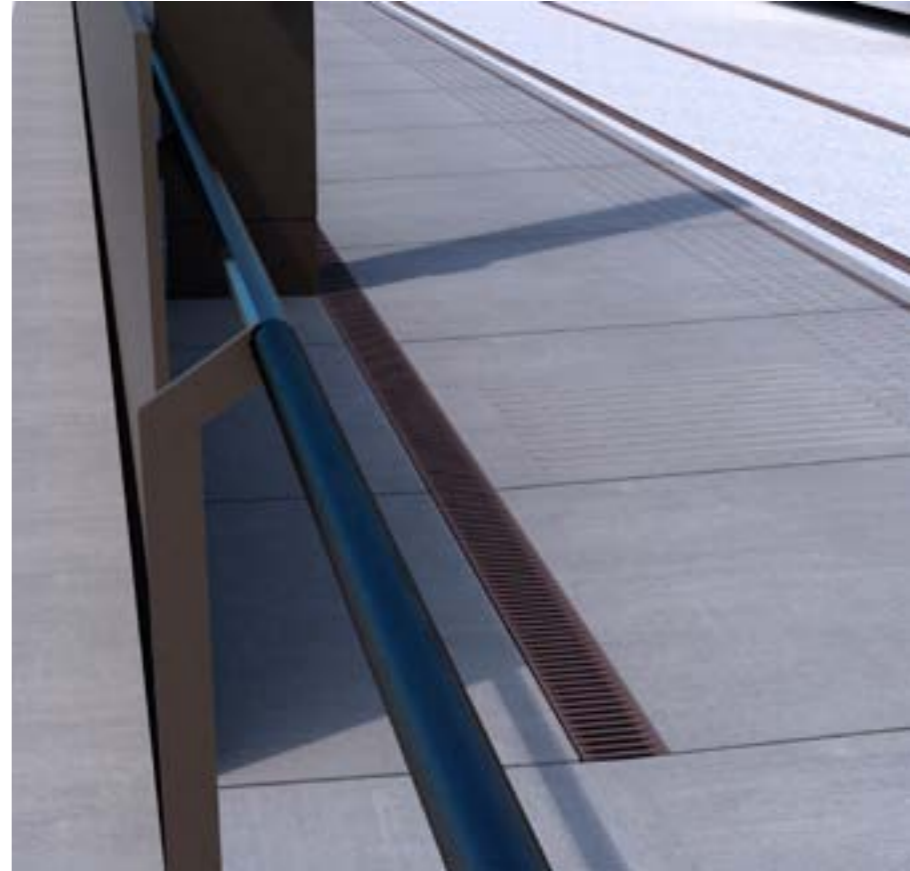
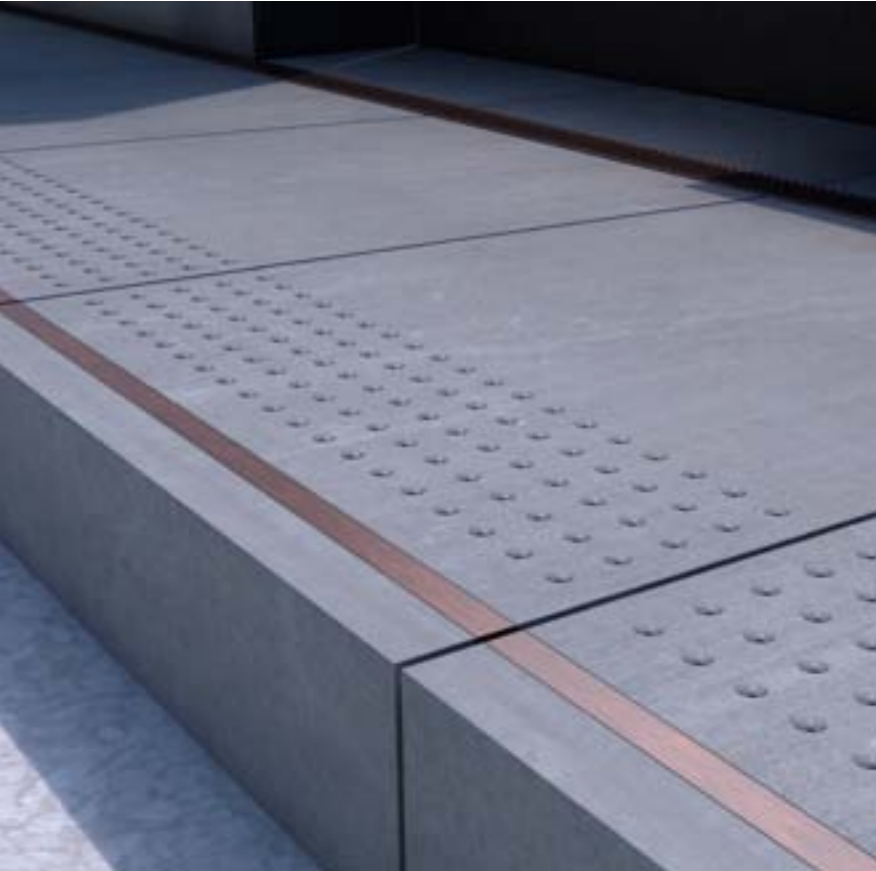





GLADSAXEVEJ

101
102
103
104
105
106
107
108
109
110
111
112
113
114
115
116
117
118
119
120
121
122
123
124
125
126
127
128
129
130
131
132
133
134
135
136
137
138
139
140
141
142
143
144
145
146
147
148
149
150
151
152
153
154
155
156
157
158
159
160
161
162
163
164
165
166
167
168
169
170
171
172
173
174
175
176
177
178
179
180
181
182
183
184
185
186
187
188
189
190
191
192
193
194
195
196
197
198
199
200



KØRELEDNINGSMASTER

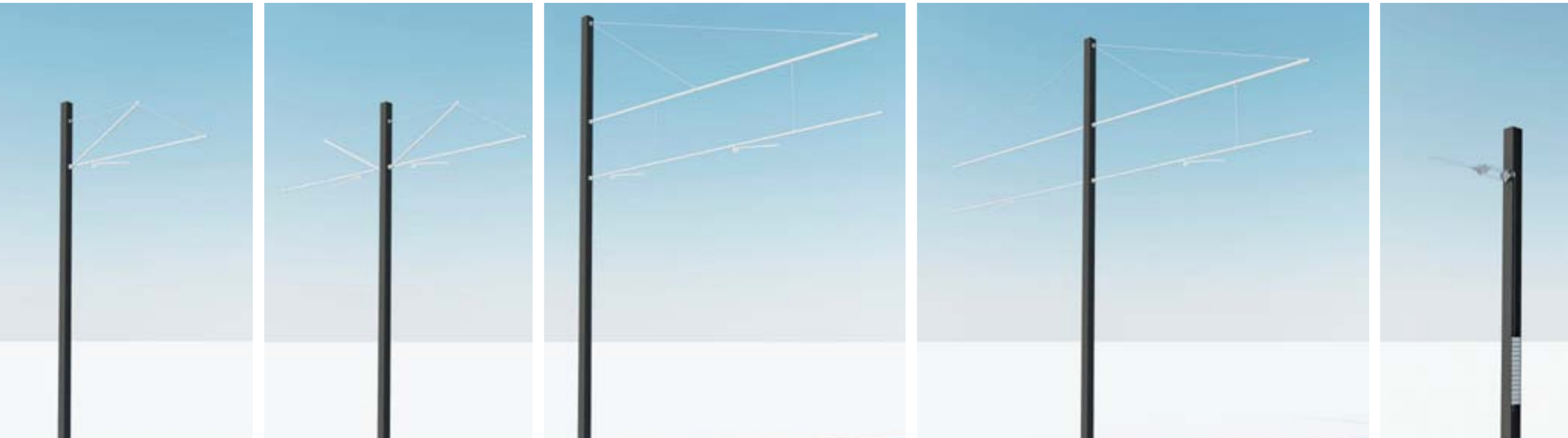

KONTROL- OG VEDLIGEHOLDELSES CENTER



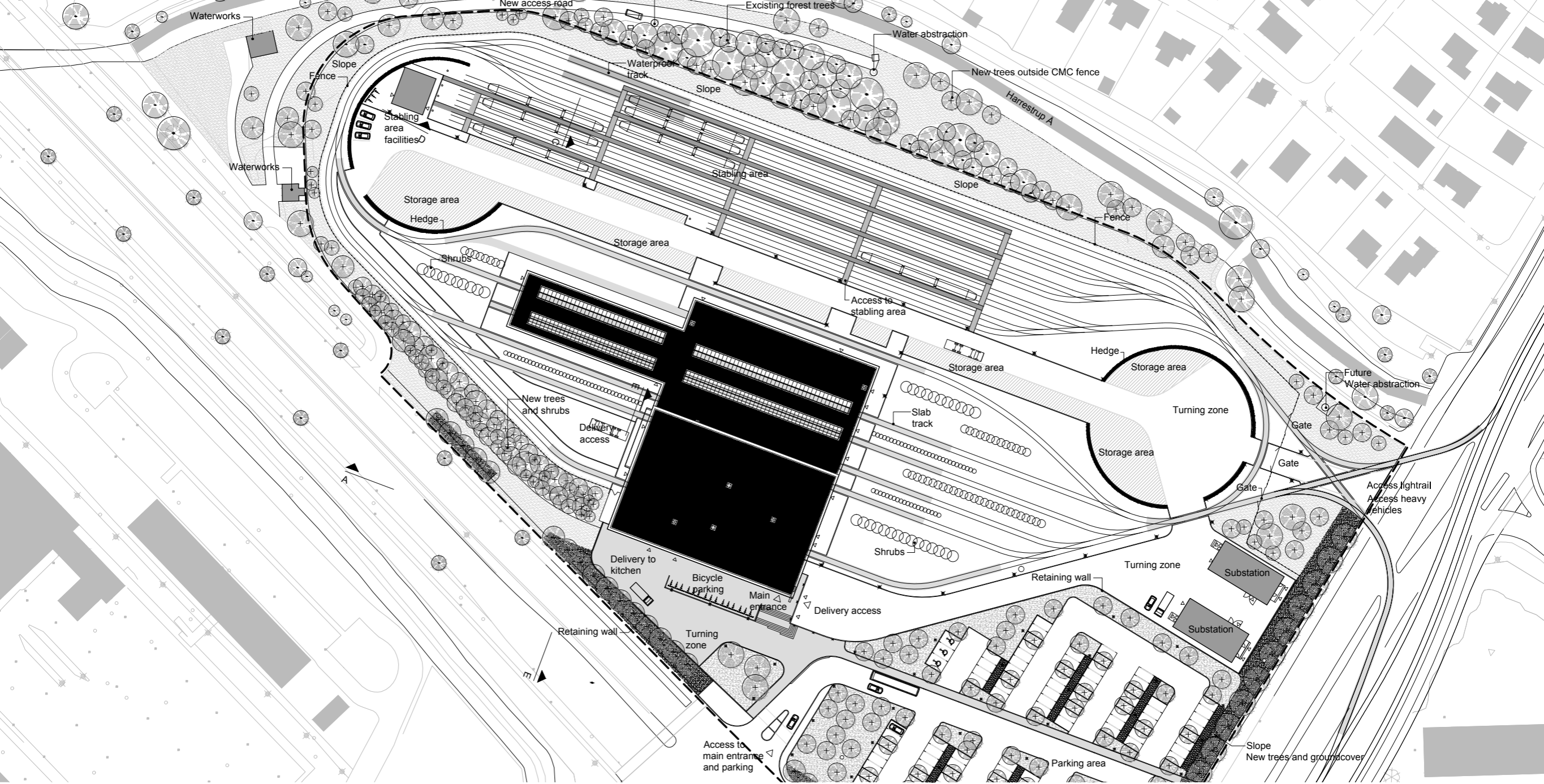

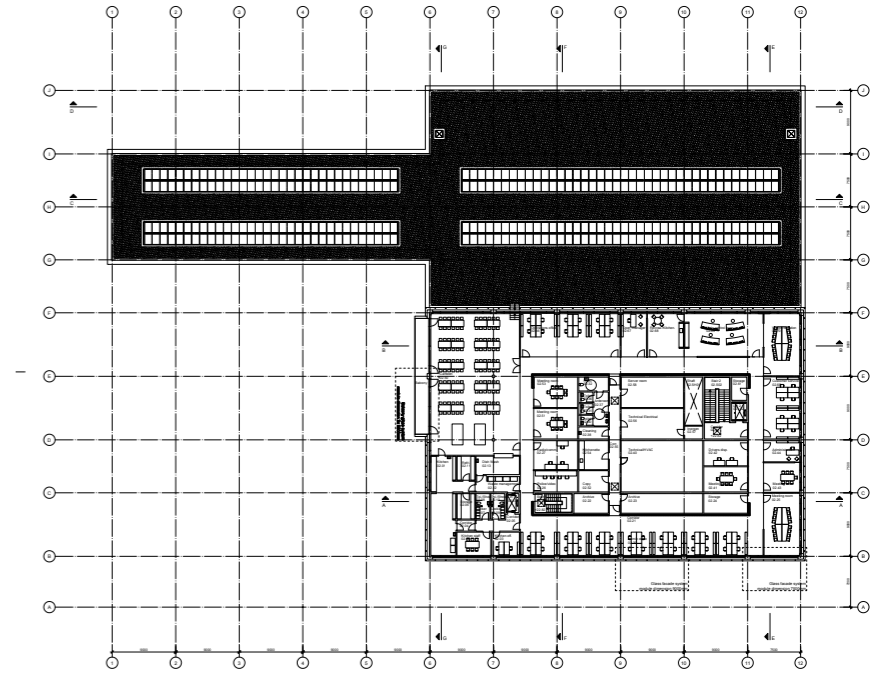
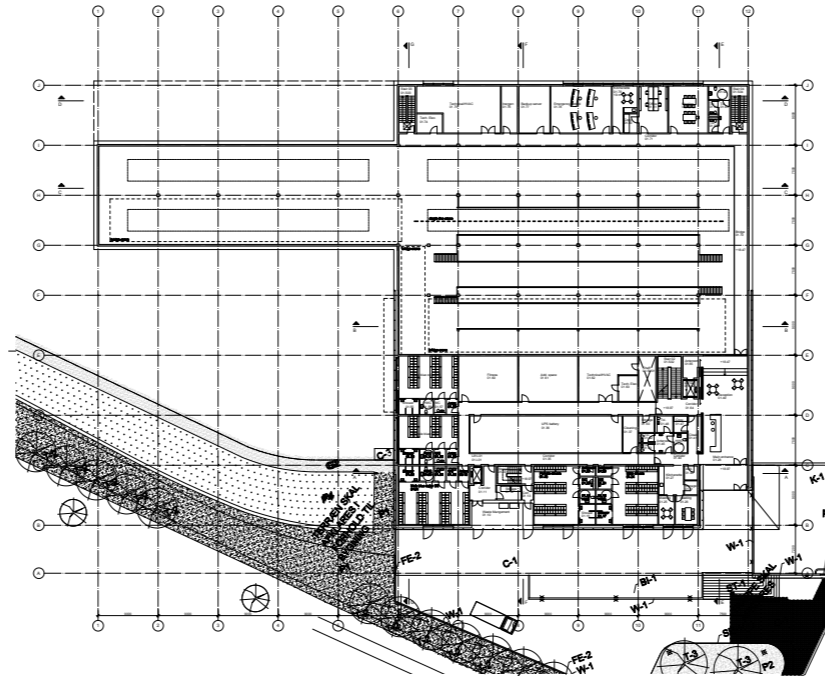
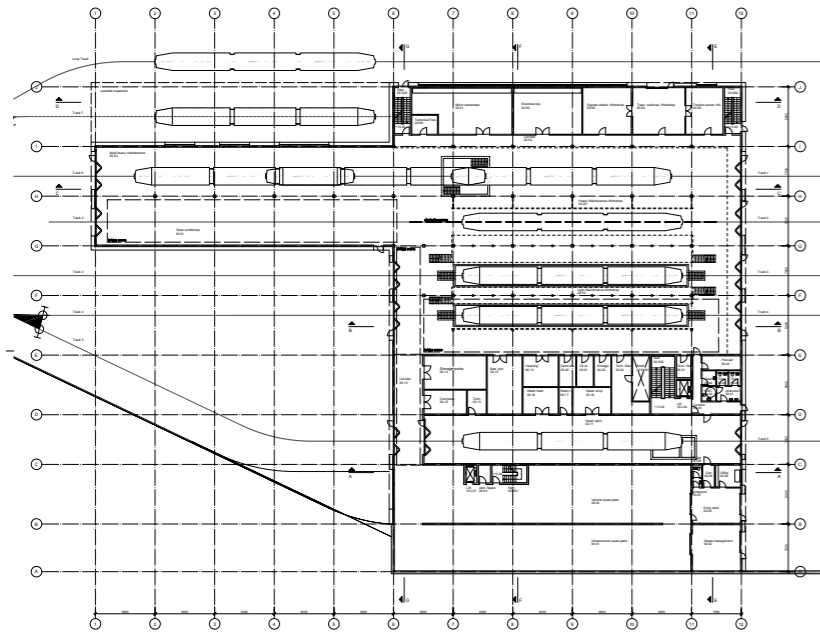

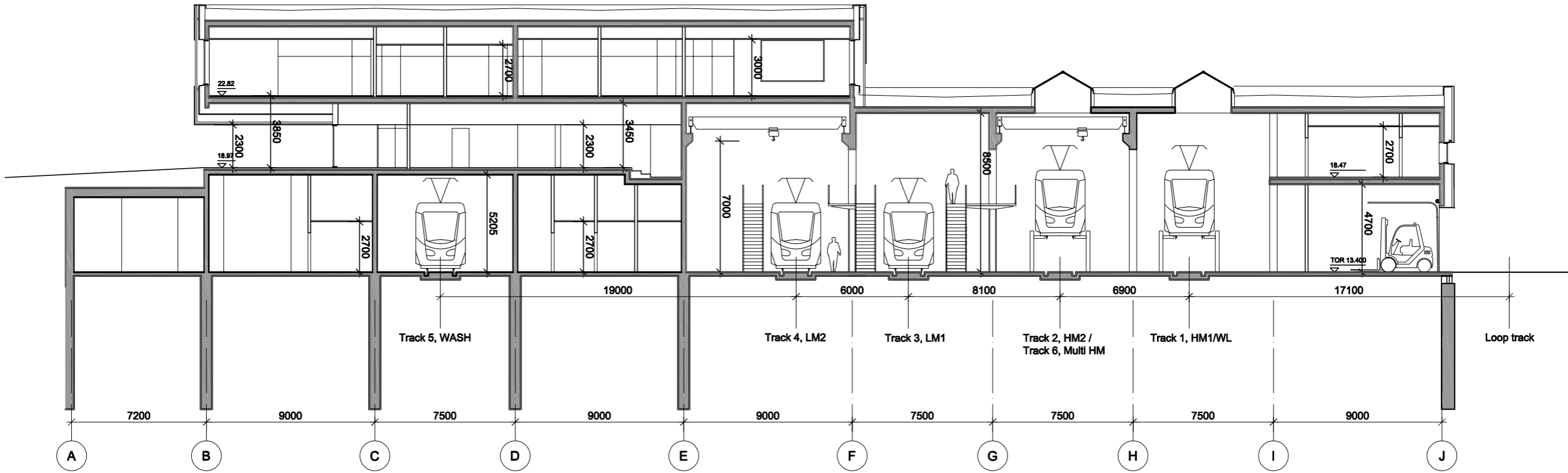

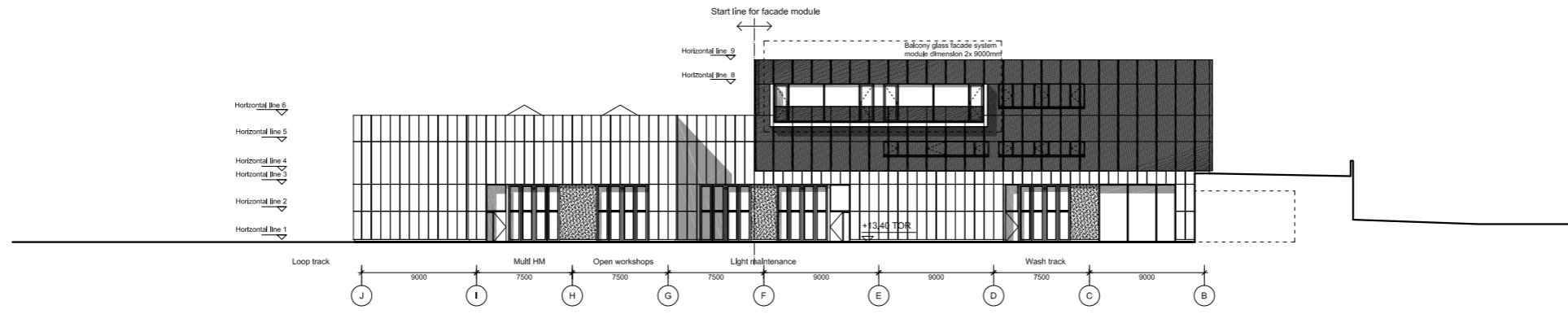

Elevation West

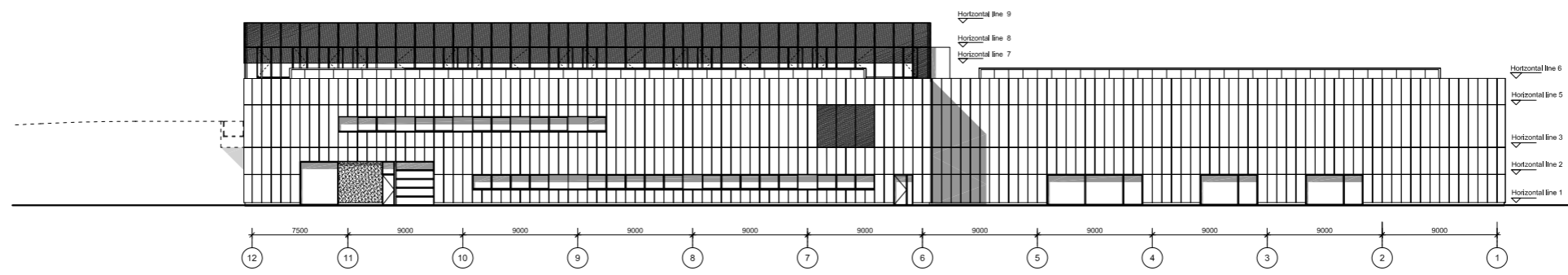

Elevation North

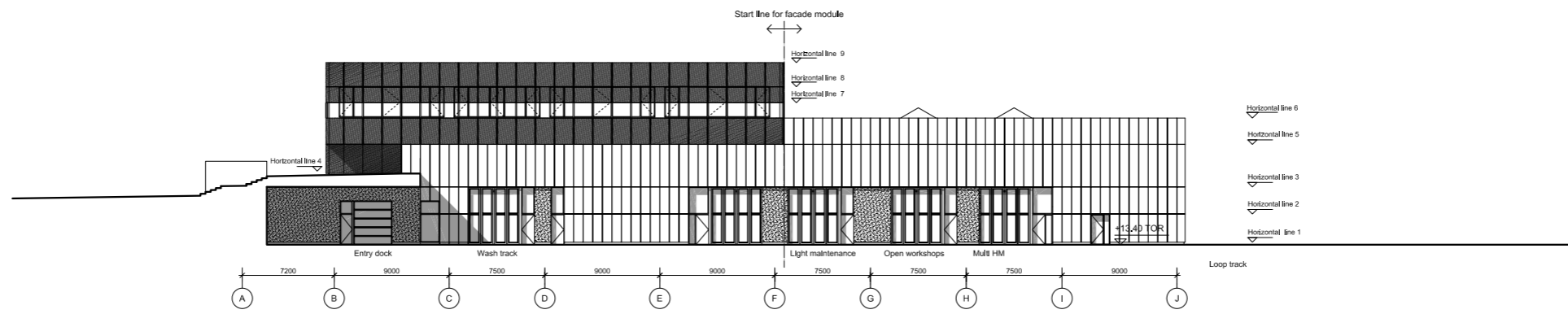

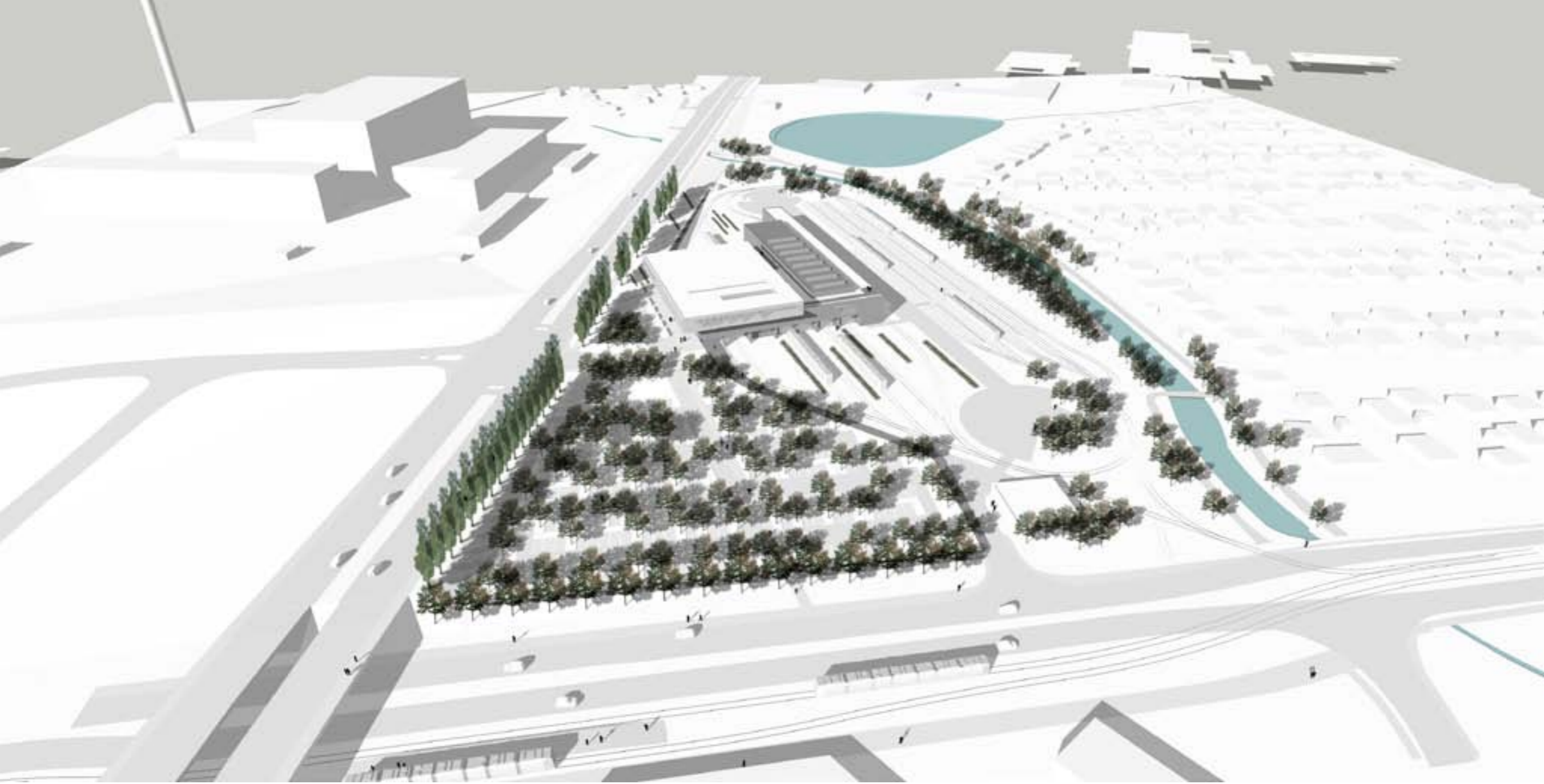

OMFORMER STATIONER





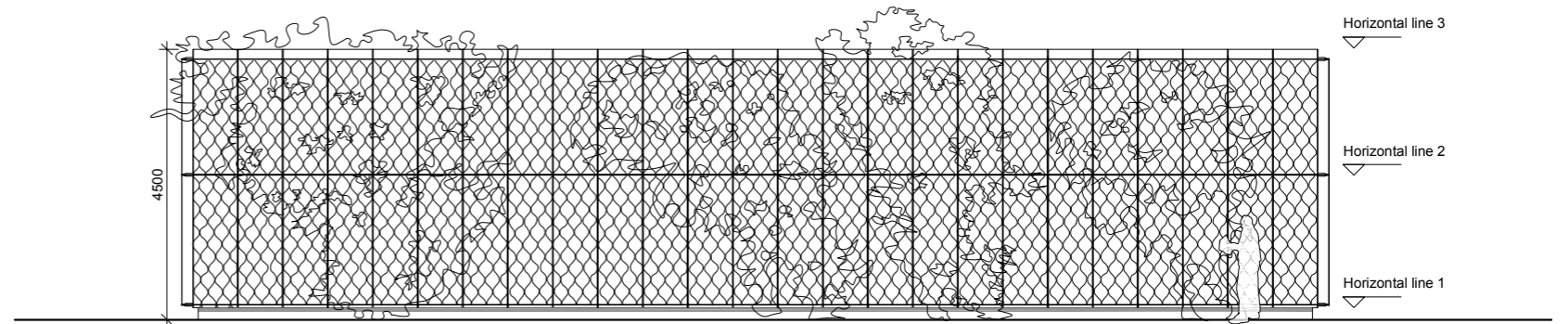
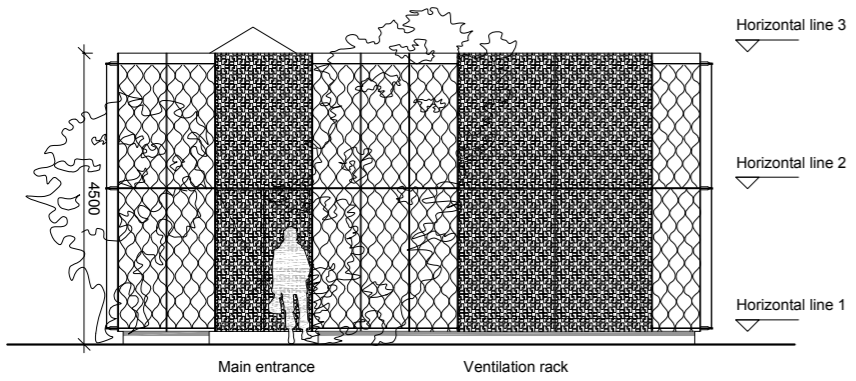

KONSTRUKTIONER









LYNGBY-TAARBÆK

GLADSAXE

HERLEV

RØDOVRE

GLOSTRUP

ALBERTSLUND

BRØNDBY

VALLENSBÆK

ISHØJ

**GOTTLIEB
PALUDAN**
ARCHITECTS